

KEN DAVIES

Quatandre

for
Trombone Quartet
(3 tenors - 1 bass)

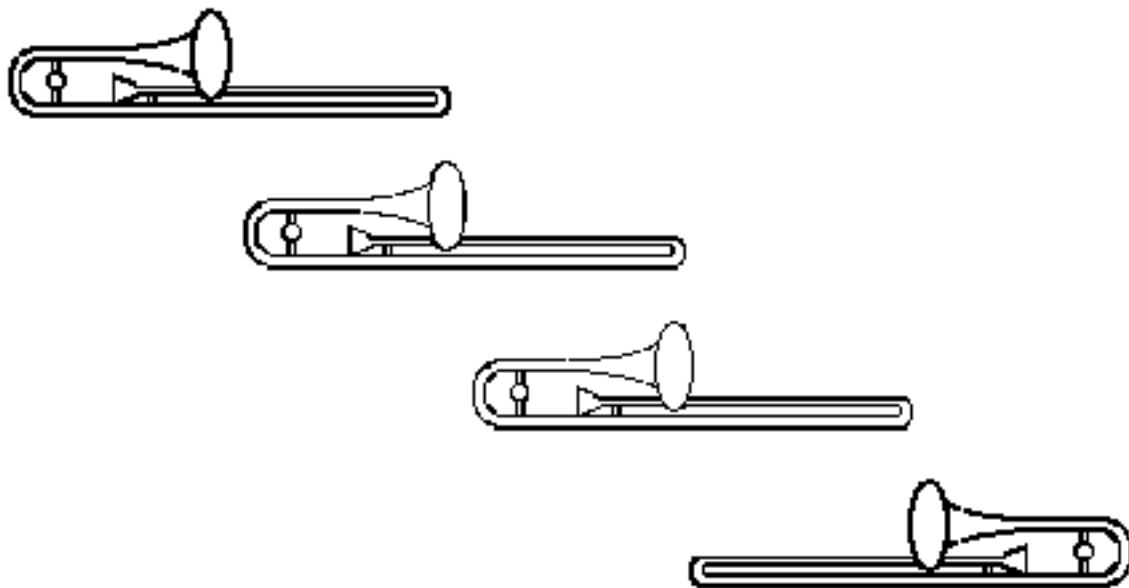

KD 106

Kenvad Music
Gautier, Mississippi
www.kendavies.net

***Quatandre* for trombone quartet or choir (7:20)**

Program Notes

The work opens its first seven measures by introducing the basic motives on which the work then develops; namely, glissando figures, pyramided chord build-ups, hand-popped mouthpiece percussive effects, and measured tremolos. The first (and last) section of the piece develop rhythmic and glissando gestures structured in a variety of meter signatures. This gives way to a section of harmonic development through chord pyramids. A two part middle section provides first a thinning of texture, then a short contrapuntal section culminating in a slower, more homophonic section before returning to material based on the the first and second sections to unify and close out the work. *Quatandre* received its world premier at the 2005 International Trombone Festival in New Orleans by the 20-member New Orleans Trombone Choir under the direction of Milton Bush.

Quatandre

for Trombone Quartet

Score

Duration: 7:20

Ken Davies

Lively ♩ = 120

Trombone 1
Trombone 2
Trombone 3
Bass Trombone

mf f mf
mf f mf
mf f mf
mf

hand pop mouthpiece

5

crescendo-decrescendo as measured tremolos
crescendo-decrescendo as measured tremolos
crescendo-decrescendo as measured tremolos
crescendo-decrescendo as measured tremolos

2

8

Musical score for measures 8-10, featuring four staves in bass clef with a 4/8 time signature. The first three staves have a dynamic marking of *f*. The fourth staff has a dynamic marking of *f* with accents (>) over the notes. The music consists of rhythmic patterns and melodic lines.

10

Musical score for measures 10-11, featuring four staves in bass clef with a 10/8 time signature. The music continues with rhythmic patterns and melodic lines.

12

Musical score for measures 12-13, featuring four staves in bass clef with a 7/8 time signature. The music includes glissando markings (*Gliss.*) in the second, third, and fourth staves.

14

Musical score for measures 14-15, measures 11-12, and measures 13-14. The score is written for four bass staves. The first system (measures 14-15) shows a complex rhythmic pattern with eighth and sixteenth notes. The second system (measures 11-12) shows a similar pattern with a key signature change to one flat. The third system (measures 13-14) shows a continuation of the rhythmic pattern with a key signature change to two flats. The bottom staff features a steady eighth-note accompaniment.

16

Musical score for measures 16-17, measures 18-19, and measures 20-21. The score is written for four bass staves. The first system (measures 16-17) shows a complex rhythmic pattern with eighth and sixteenth notes. The second system (measures 18-19) shows a similar pattern with a key signature change to one flat. The third system (measures 20-21) shows a continuation of the rhythmic pattern with a key signature change to two flats. The bottom staff features a steady eighth-note accompaniment.

18

Musical score for measures 18-19, measures 20-21, and measures 22-23. The score is written for four bass staves. The first system (measures 18-19) shows a complex rhythmic pattern with eighth and sixteenth notes. The second system (measures 20-21) shows a similar pattern with a key signature change to one flat. The third system (measures 22-23) shows a continuation of the rhythmic pattern with a key signature change to two flats. The bottom staff features a steady eighth-note accompaniment.

incomplete excerpt - score is 21 pages